

Installation Note

Agilent Technologies ESA Spectrum Analyzers Digital Signal Processing and Fast ADC (Option B7D) and RF Communications Hardware (Option B7E)



Agilent Technologies

Part Number E4402-90103 Supersedes: E4402-90088

Printed in USA July 2005



E4402-90103

Notice.

The information contained in this document is subject to change without notice.

Agilent Technologies makes no warranty of any kind with regard to this material, including but not limited to, the implied warranties of merchantability and fitness for a particular purpose. Agilent Technologies shall not be liable for errors contained herein or for incidental or consequential damages in connection with the furnishing, performance, or use of this material.

Microsoft® is a U.S. registered trademark of Microsoft Corp.

Introduction

Use this procedure to retrofit Digital Signal Processing and Fast ADC (Option B7D), and RF Communications Hardware (Option B7E) simultaneously into an Agilent E4402B, E4404B, E4405B, or E4407B spectrum analyzer. These two options cannot be retrofitted separately; they must be retrofitted simultaneously.

The High Stability Frequency Reference (Option 1D5) is required to meet the specified performance of measurements which use the Option B7D and B7E hardware. Also, the Enhanced Memory (Option B72) is required to install any personality which makes use of Option B7D and B7E. Options 1D5 and B72 should be installed prior to retrofitting Options B7D and B7E.

To verify if these options are installed in the analyzer, press **System, More 1 of 2, Show System**. If the options exist, there should be a listing for the 1D5, Precision Frequency Reference and the B72, Enhanced Memory. If both options exist, the B7D and B7E hardware can be installed and will function as expected. If either one or both of the options are not installed into the analyzer, upgrade kits are available. See www.agilent.com/find/esa-e_upgrades for ordering information.

Products Affected:	E4402B E4404B E4405B E4407B
Serial Numbers:	Any
Options:	B7D and B7E
To Be Performed By:	(X) Agilent Technologies Service Center (X) Personnel Qualified by Agilent () Customer
Estimated Installation Time:	1.5 Hours
Estimated Verification Time:	1.5 Hours
Additional Recommended Task:	Agilent recommends a full calibration be performed to verify instrument specifications

To ensure that this newly installed option is functioning properly, the procedure that follows includes the requirement of performing certain adjustments and performance verification tests. However, the completion of these tests does not guarantee that the instrument meets all advertised specifications.

Software is required to perform the required adjustments, and can be used to automate the performance verification testing. Information on how to obtain this software can be found at: www.agilent.com/find/calibrationsoftware

While Agilent does recommend that a full calibration be performed after the installation of this upgrade, the end user must ultimately determine whether they want this service or not. If a full calibration is required, arrangements regarding the level of calibration must be made between the end user and the calibration provider.

Installation Kit Parts Lists

Option B7D, DSP and FADC, and Option B7E, RF Comms Hardware Retrofit Kit

Item	Description	Part Number
1	DSP and FADC Assembly (A7A7)	E4401-60088
2	Digital Demod RF Assembly (A7A8)	E4401-60295
3	Cable Assembly, Digital Demod RF Input (W29)	E4402-60024
4	Cable Assembly, 50 MHz Amptd Ref Out (W30)	E4402-60023
5	Cable Assembly, Digital Demod IF Input (W31)	E4402-60021
6	Cable Assembly, Digital Demod IF Output (W32)	8120-8866
7	Cable Assembly, DSP Sample Rate (W33)	8120-8867
8	Cable Assembly, Digital Demod DSP IF (W34)	E4402-60027
9	Cable Clip	5041-7250
10	Firmware Upgrade Kit	Option UE2
11	Cable Assembly, BNC	8120-2682
12	Option B7D/B7E Retrofit Kit Installation Note	this note

Tools Required

T-10 TORX screwdriver

T-15 TORX screwdriver

5/16-inch open-ended wrench

Torque Settings

To avoid potential RFI leakage and prevent connector damage, tighten screws and RF coax cable connectors to the following torque limits:

Item	Torque	
	In-lb	N-cm
SMA Connectors	8.5	95
3-mm, T-10 TORX screws	9	102
4-mm, T-15 TORX screws	21	236

WARNING Before you disassemble the instrument, turn the power switch OFF and unplug the instrument. Failure to unplug the instrument can result in personal injury.

CAUTION Electrostatic discharge (ESD) can damage or destroy electronic components. All work on electronic assemblies should be performed at a static-safe workstation. Refer to the documentation that pertains to your instrument for information about static-safe workstations and ordering static-safe accessories.

Procedure

Dress Cover Removal

1. Refer to [Figure 1](#). Disconnect the analyzer from ac power (1).

Figure 1 Dress Cover and Rear Frame Removal

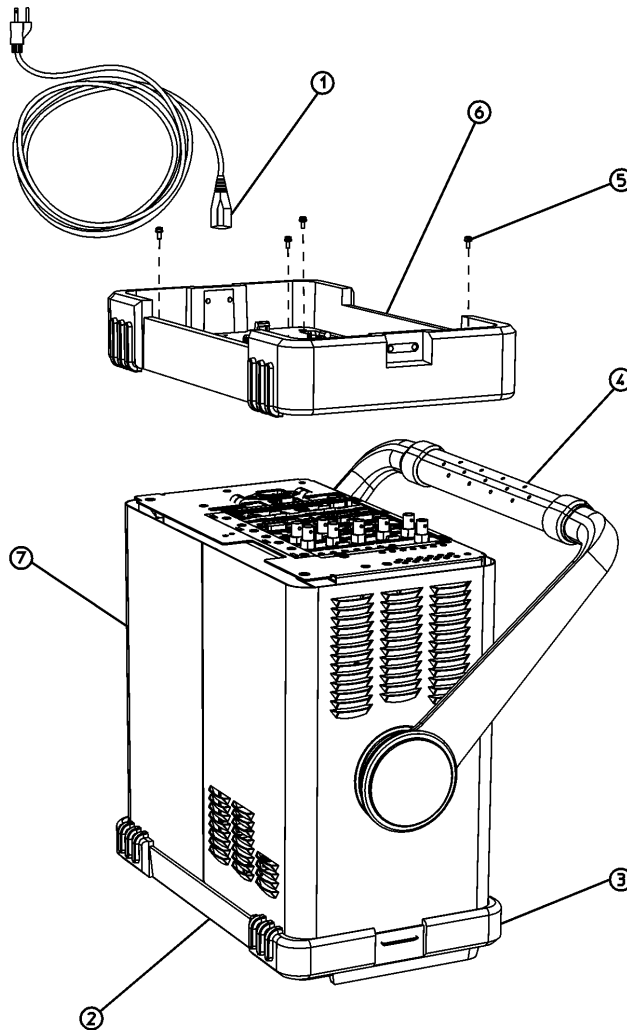

dl71b

2. Remove any adapters or cables (2) connected to the front frame.
3. Carefully place the analyzer on the work surface with the front frame (3) facing down.
4. Position the handle (4) as shown.
5. Remove the four screws (5) that hold the rear frame and dress cover in place.
6. Remove the rear frame (6).
7. Pull the dress cover (7) off towards the rear of the analyzer.

Chassis Cover Removal

1. Lay the analyzer flat as shown in [Figure 2](#).

Figure 2 Chassis Cover Removal

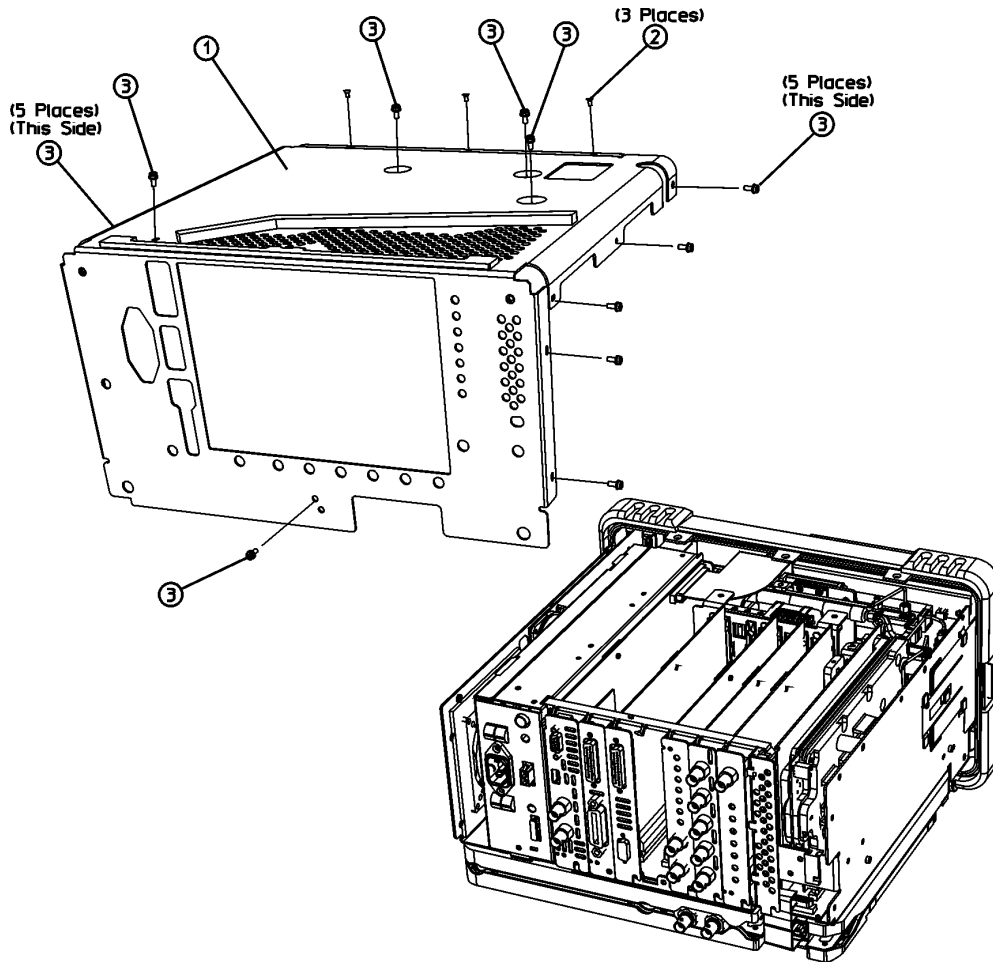

dl72b

2. Remove the 15 screws (2) and (3) attaching the chassis cover to the chassis. Note that the number of screws attaching the chassis cover may vary with the number and types of options installed.
3. Remove the chassis cover (1) from the chassis.

A1 Front Frame Assembly

CAUTION Use ESD precautions when performing this replacement procedure.

Extension

The A1 front frame assembly can be extended from the instrument without detaching any connections.

1. Refer to [Figure 3](#). With the instrument still on its face, remove the five screws (1), two on the bottom side and three on the top of the instrument, that secure the front frame to the RF assembly and chassis cover.

Figure 3 A1 Front Frame Assembly Removal

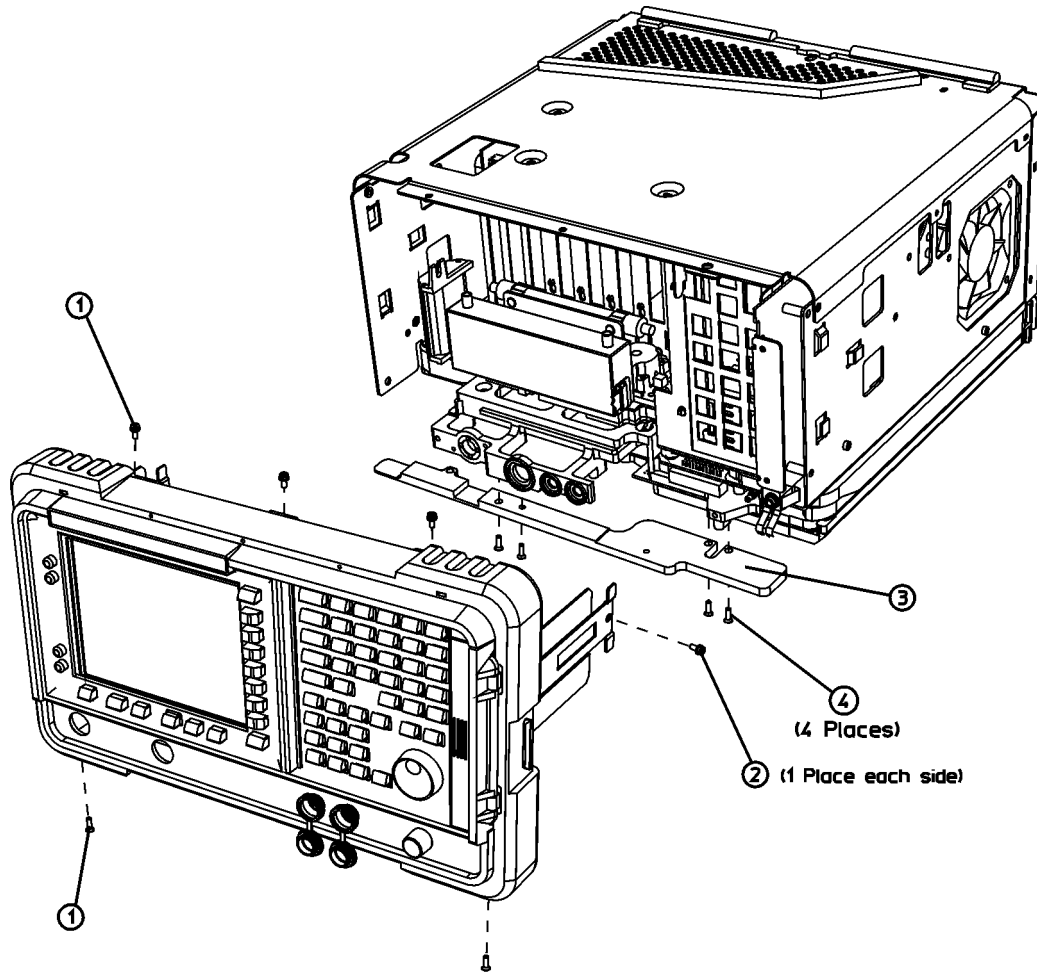

sl7118b

2. Place the instrument with the top side facing up and remove the remaining two screws (2) that secure the front frame subpanel to the chassis.
3. Slide the front frame forward until it catches on the tabs on the sides of the chassis.

Removal

Refer to [Figure 3](#). To completely remove the A1 front frame assembly, perform the procedure “[Extension](#)” on [page 8](#), then continue with the following steps:

1. Refer to [Figure 4](#). Disconnect the ribbon cable (1) from the A1A1 front panel interface board. Analyzers with Option B7B will have a second ribbon cable connecting to A1A1. Disconnect the second ribbon cable if present.

Figure 4 **Front Frame Ribbon Cable**

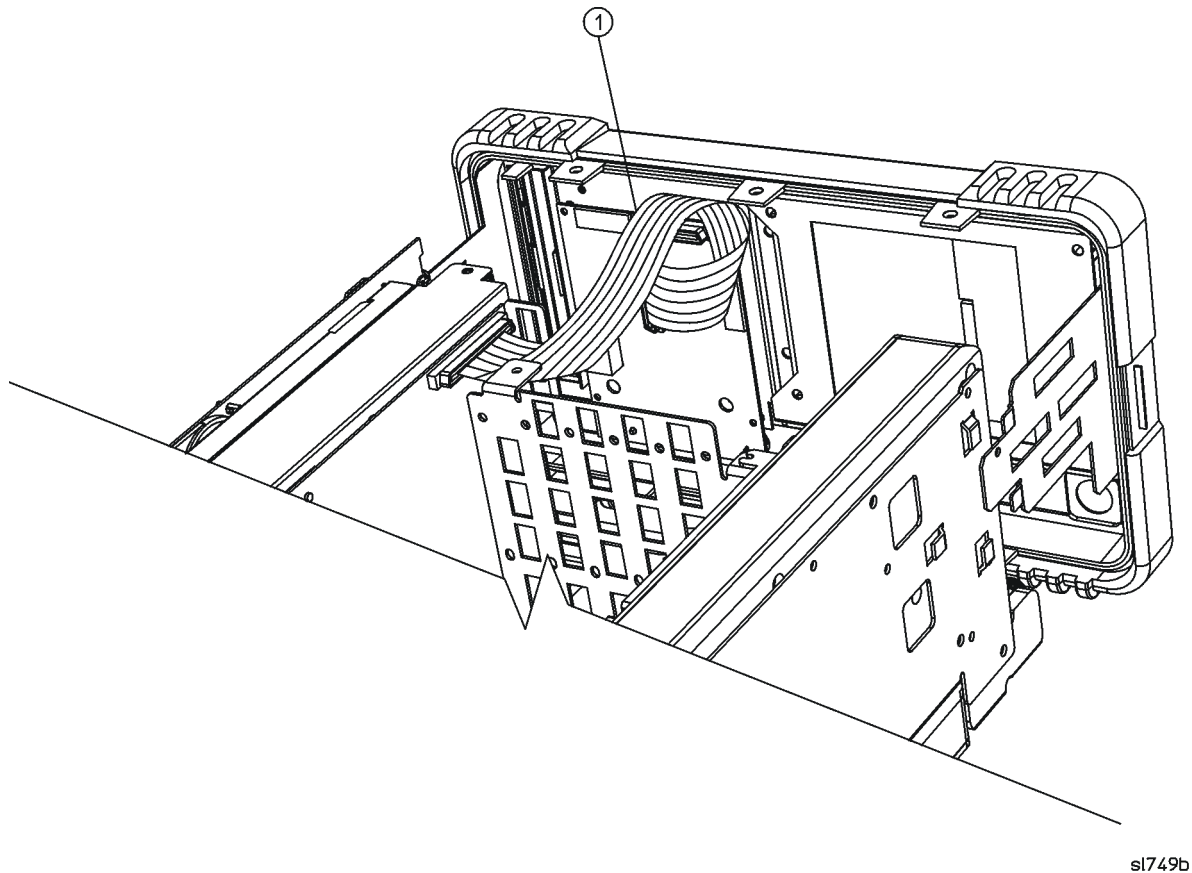

sl749b

2. Carefully pull the sides of the front frame subpanel away from the chassis and over the tabs on the chassis.
3. Slide the front frame forward to disengage from the chassis assembly.

A8A4 LO Amp/IF Switch Assembly

This procedure applies to the ESA E4404B, E4405B, and E4407B only. If the analyzer is an ESA E4402B, continue with the procedure “[Install New Coaxial Cables](#)” on page 11.

CAUTION Use ESD precautions when performing this replacement procedure.

NOTE The LO amplifier and IF switch (LOIS) assembly can be removed without removing the RF assembly.

Removal

1. Refer to [Figure 5](#). Disconnect any cables and loads (1) from the LOIS assembly.

Figure 5 Removing the LO Amplifier/IF Switch Assembly

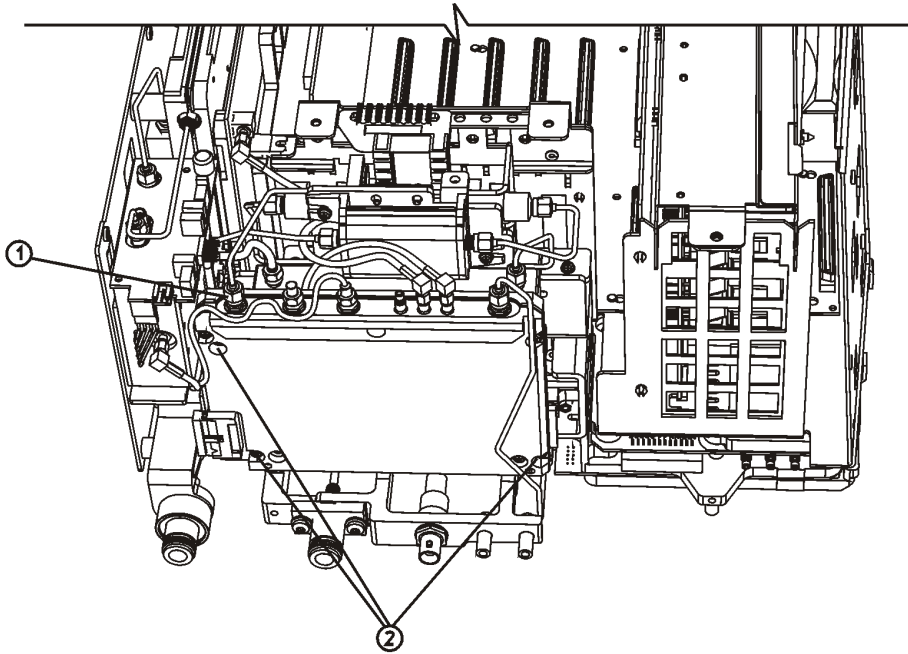

sl775b

2. Remove the three screws (2) and remove the LOIS assembly.

Install New Coaxial Cables

- Refer to [Figure 6](#). Locate the end of W2, the 21.4 MHz IF cable (2) connected to the A8A1 3 GHz RF Assembly at A8A1A1P5. This cable is labeled with a red band. Disconnect W2 from A8A1A1P5 and from the A3 IF assembly at A3J2. Gently pull on the end of W2 previously attached to A8A1A1P5 to draw the cable through the microcircuit area. Note the path taken by the end of W2 that was previously connected to A3J2; this will be the same path used to route the new cables to be installed.

Figure 6 Original Cable Identification and Routing

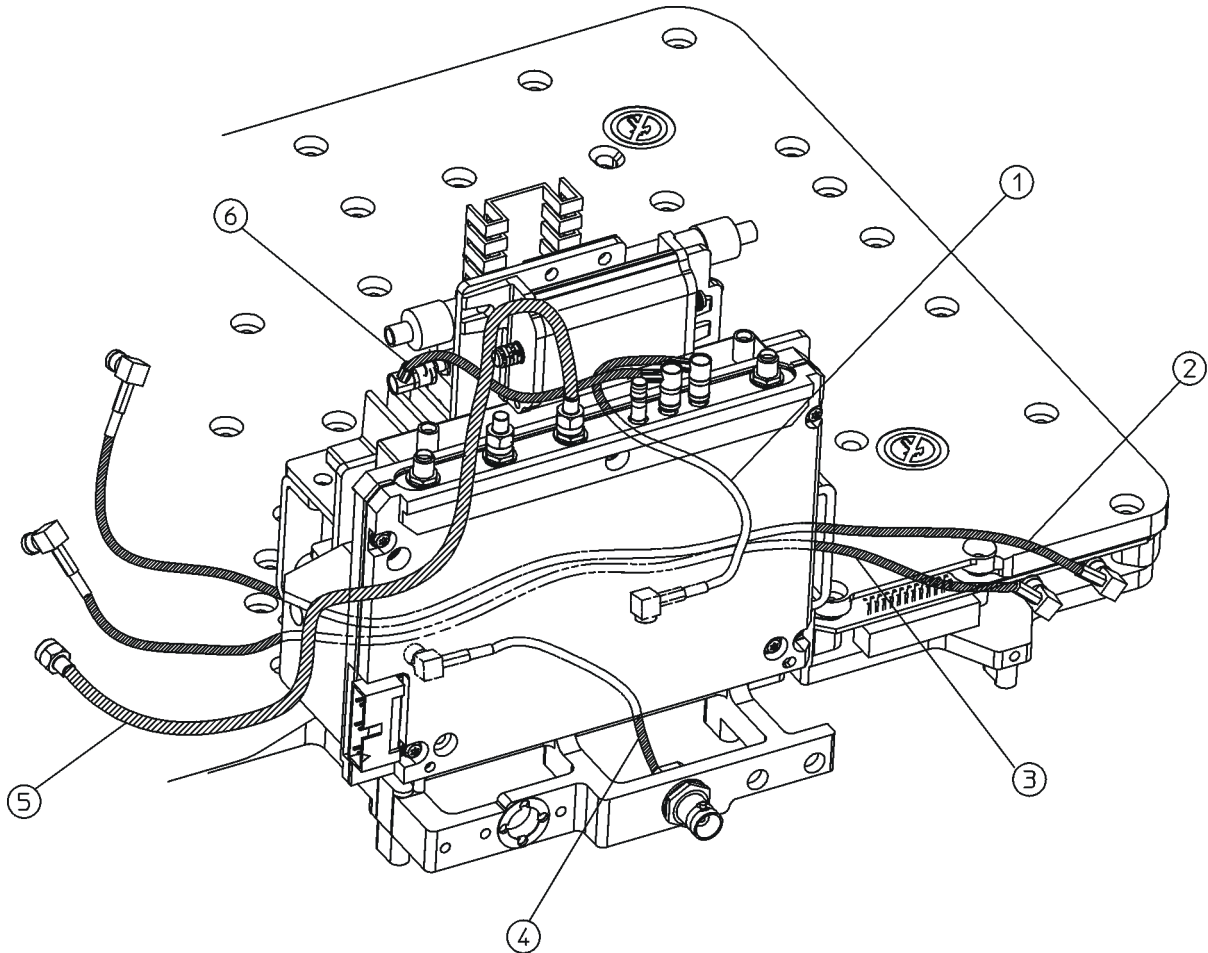

sl715b

- Turn the analyzer upside down on the work surface. Locate the A8A1W4 50 MHz External Amptd Ref Out cable (4). Disconnect the SMB end of A8A1W4 from the A8A1 3 GHz RF Assembly at A8A1A2J4. Loosen the nut securing the BNC connector end of A8A1W4 from the “midsection”. Remove and save the nut, washer, and O-ring securing the BNC connector from the midsection. This hardware will be used later for installing the new cable.

- Refer to [Figure 7](#). Locate W34, the 50 MHz Amptd Ref Out cable, in the retrofit kit. This cable has a BNC connector on one end and a MMCX connector on the other. Insert the BNC connector into the hole in the midsection where A8A1W4 was removed (2). Place the O-ring over the outside portion of the BNC connector. Place the washer over the O-ring. Secure with the nut removed in [step 4](#). Torque the nut to 21 in-lbs.

Figure 7 **New Cable Routing**

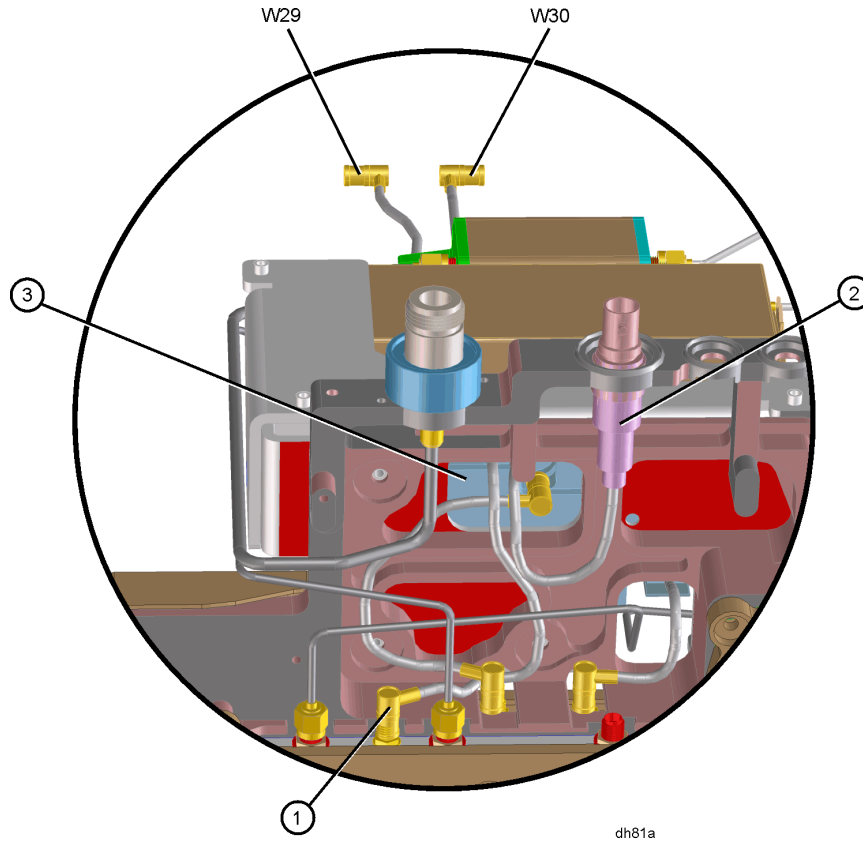

- Locate W29, the Digital Demod RF Input cable. This cable has a SMB connector on one end, a MMCX connector on the other, and a brown label on each end. Connect the SMB end of the cable to A8A1A2J4 (1).
- Feed the remaining ends of W34 and W29 through the hole in the midsection (3) as shown in [Figure 7](#).
- Refer to [Figure 6](#). Turn the analyzer right side up on the work surface. Locate W31, the Digital Demod IF Input cable, in the retrofit kit. This cable has a red label at each end. Connect the end with the SMB connector to the A8A1 3 GHz RF Assembly at A8A1A1P5. Route W31, W29, and W34 below the A8A5 Input Attenuator and to the left side of the A8A2 Second Converter as indicated in [Figure 6](#). This should be the same route used by the W2 cable removed in [step 3](#).

9. Refer to [Figure 8](#). Newer analyzers should have a multi-cable clip (1) installed as indicated in [Figure 8](#). If the multi-cable clip is not already installed, install the clip included in the retrofit kit. It will snap into the holes along the front end of the card cage near slots 4 and 5.

Figure 8 **Digital Demod RF Assembly Cable Clip**

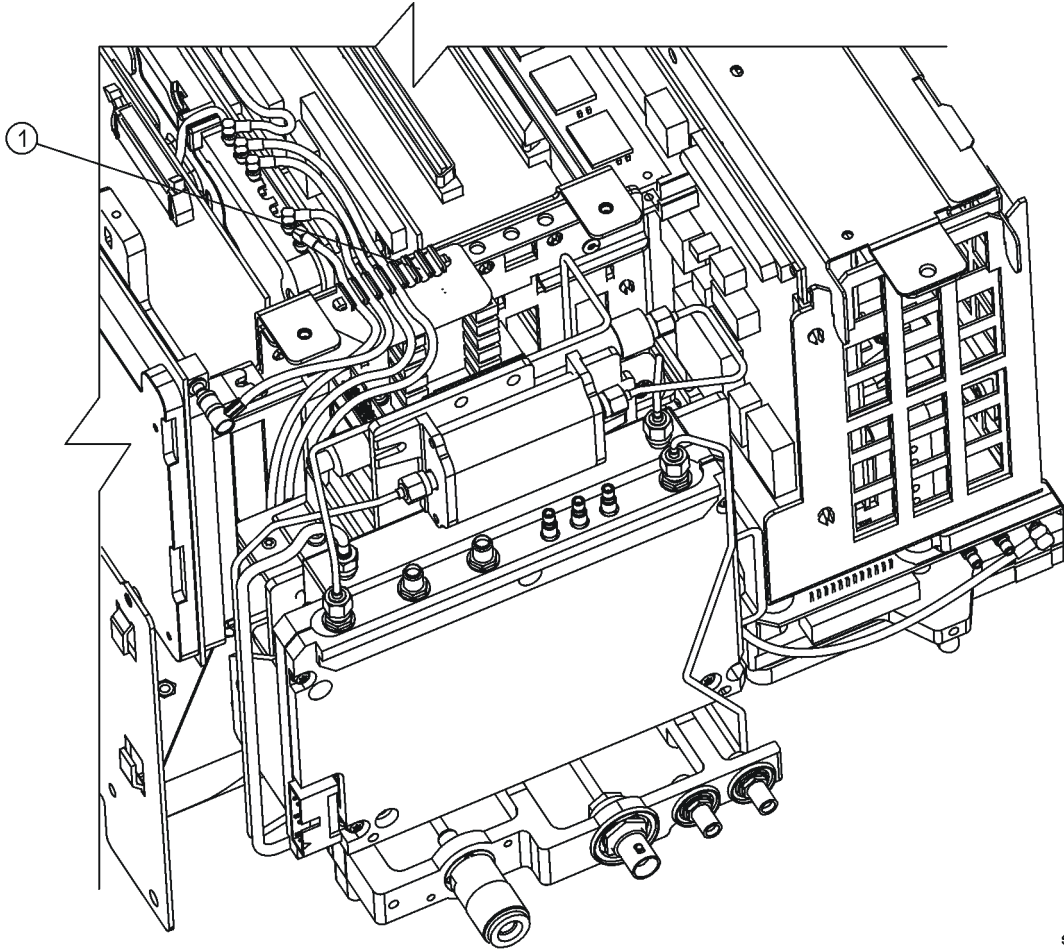

sl75c

Install A7A7 DSP and FADC Assembly, and A7A8 Digital Demod RF Assembly

1. Refer to [Figure 9](#). Loosen but do not remove all 9 of the screws (1) securing the boards and blank plates at the rear of the chassis.

Figure 9 Instrument, Rear View

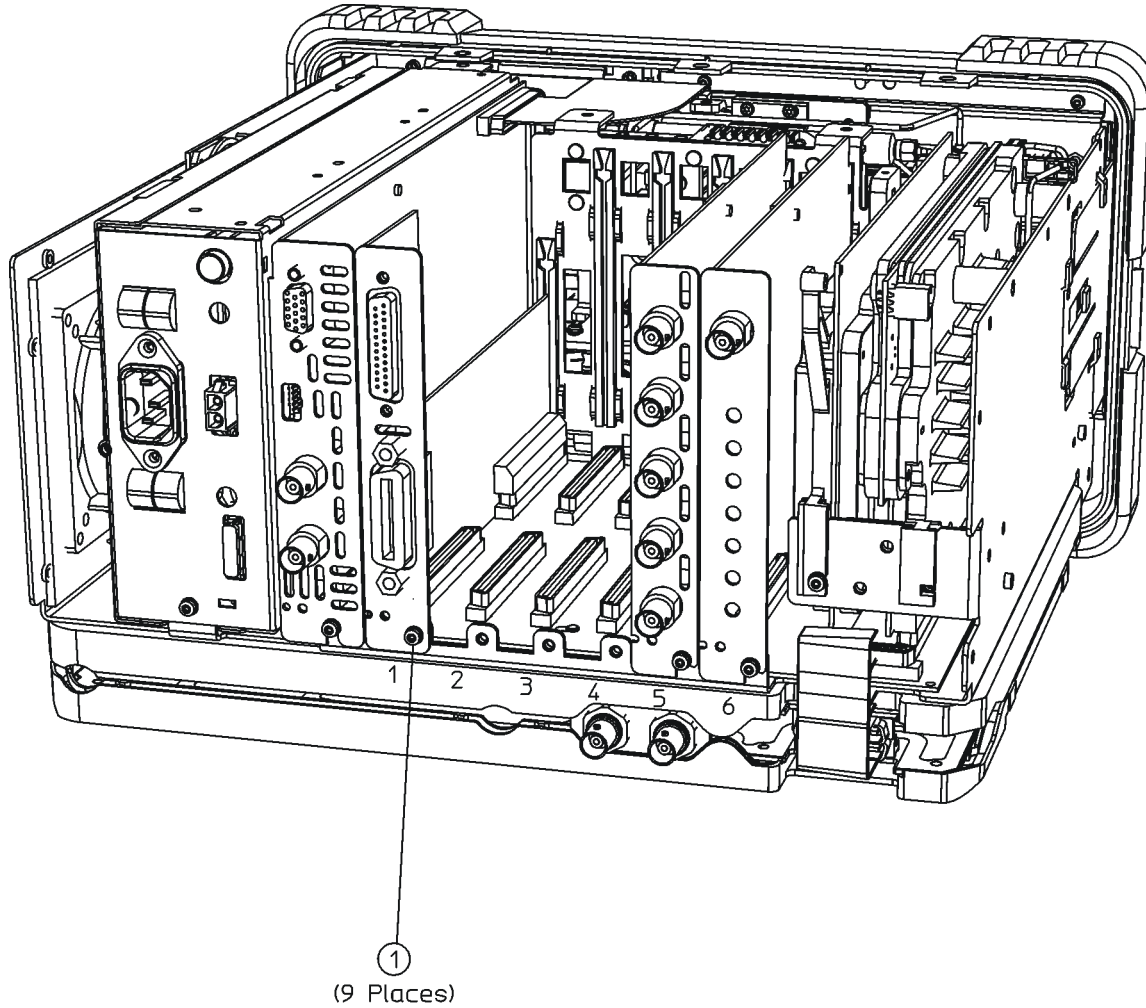

dl79b

2. Refer to [Figure 10](#). Remove the vibration support bar (1) at the top rear of the instrument by pressing in the locking tabs (2) and rotating the bar upward. The bar can be removed by sliding it out of the holes in each assembly.

CAUTION The vibration support bar can break easily if it is forced. Remove it with care.

Figure 10 Removing the Vibration Support

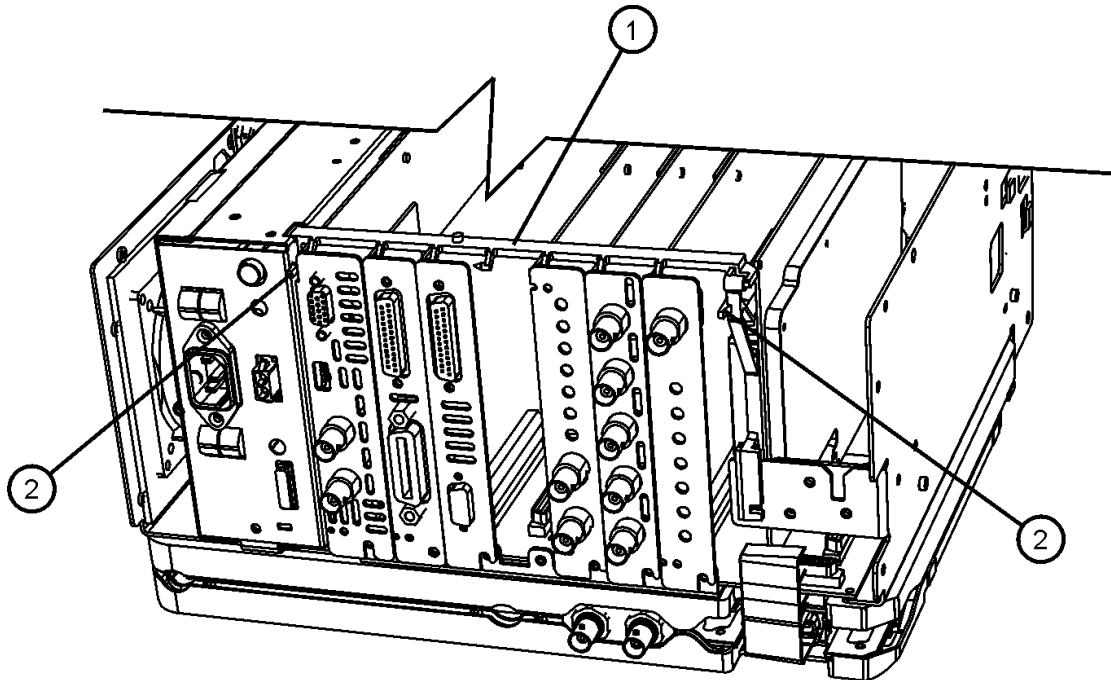

dl78b

3. The preferred slot for the A7A8 Digital Demod RF Assembly is slot 5. However, it can be inserted in either slot 2, 3, 4, or 5. The preferred slot for the A7A7 DSP and FADC Assembly is slot 4. However, it can be installed in either slot 2, 3, or 4. A7A7 and A7A8 board assemblies should always occupy adjacent slots.

NOTE The remainder of the procedure will assume that assembly A7A8 will be installed in slot 5 and assembly A7A7 will be installed in slot 4.

4. Refer to [Figure 9](#). Remove the single screw (1) securing each of the desired blank chassis panel slots.
5. Carefully pull up on the blank panel to remove it from the analyzer.

6. Refer to [Figure 11](#). Locate the A7A8 Digital Demod RF (DDRF) Assembly and the W33 Sample Rate cable assembly in the retrofit kit. The W33 cable has MMCX connectors on each end and is not labeled at either end.

Figure 11 **Digital Demod RF Board Sample Rate Cable Routing**

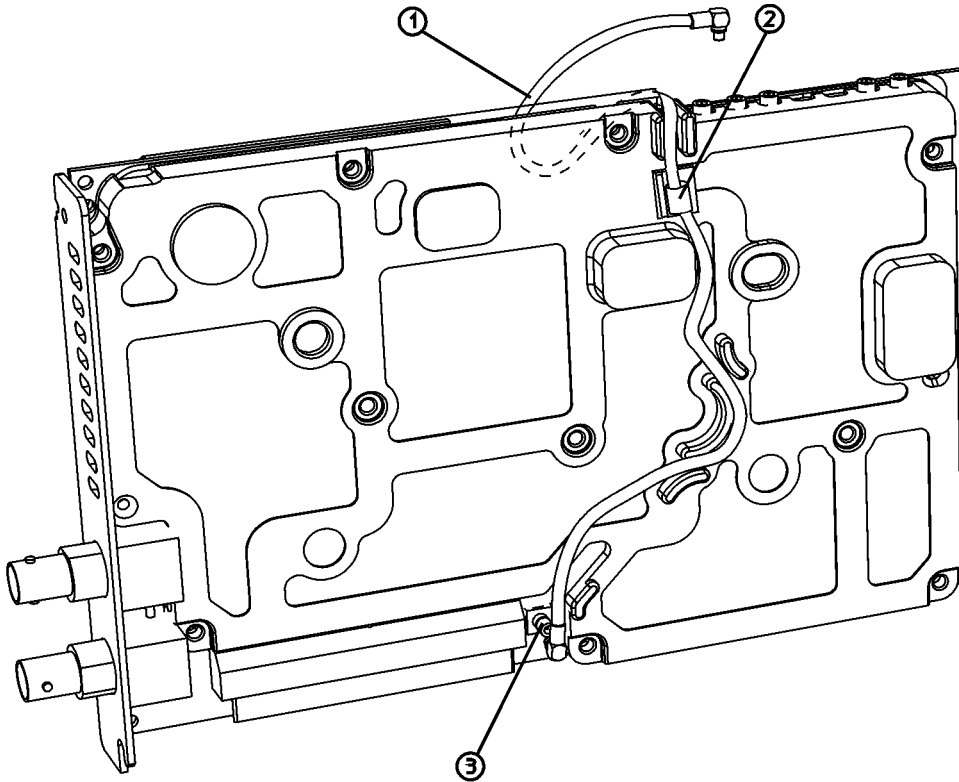

sl720c

7. Connect one end of W33 to A7A8J12 (3) as shown in [Figure 11](#). Dress the cable into the groove of the shield and secure it into the cable clip (2).

8. Refer to [Figure 12](#). Lower the A7A8 DDRF Assembly into the card cage being careful not to pinch the cables and plug it into Slot 5 (1) on the motherboard.

Figure 12 **Digital Demod RF Board Option Slot**

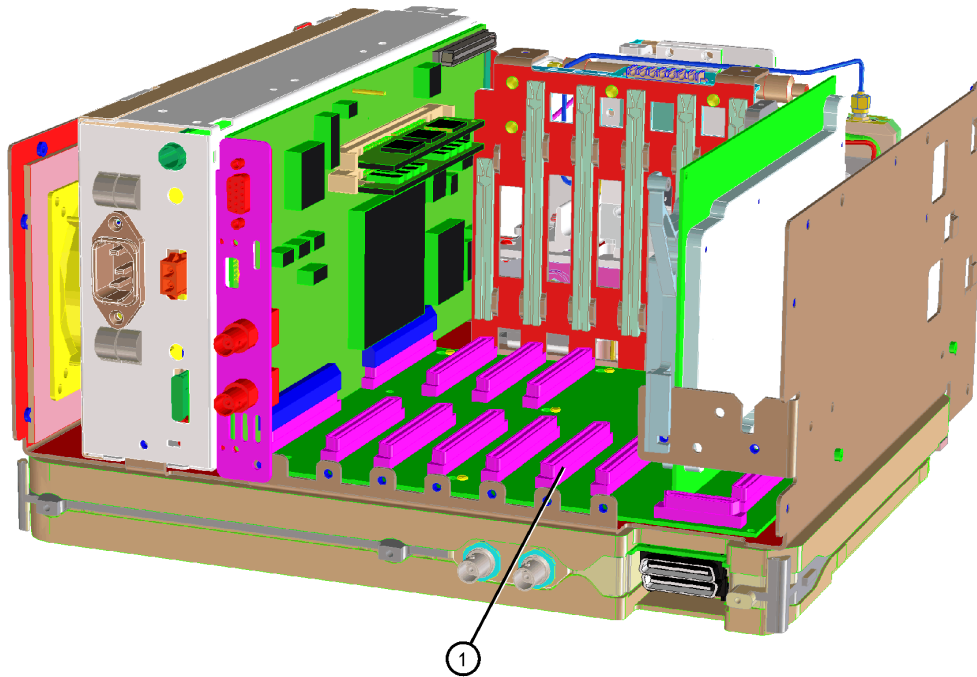

sl72c

9. Locate the A7A7 DSP and FADC Assembly and the W34 DSP IF cable assembly. W34 has MMCX connectors and green labels on each end.

10. Refer to [Figure 13](#). Connect one end of W34 to A7A7JP5 (3). Connect the remaining end of W33 Sample Rate cable to A7A7P4 (2).

Figure 13 **Digital Signal Processor Board**

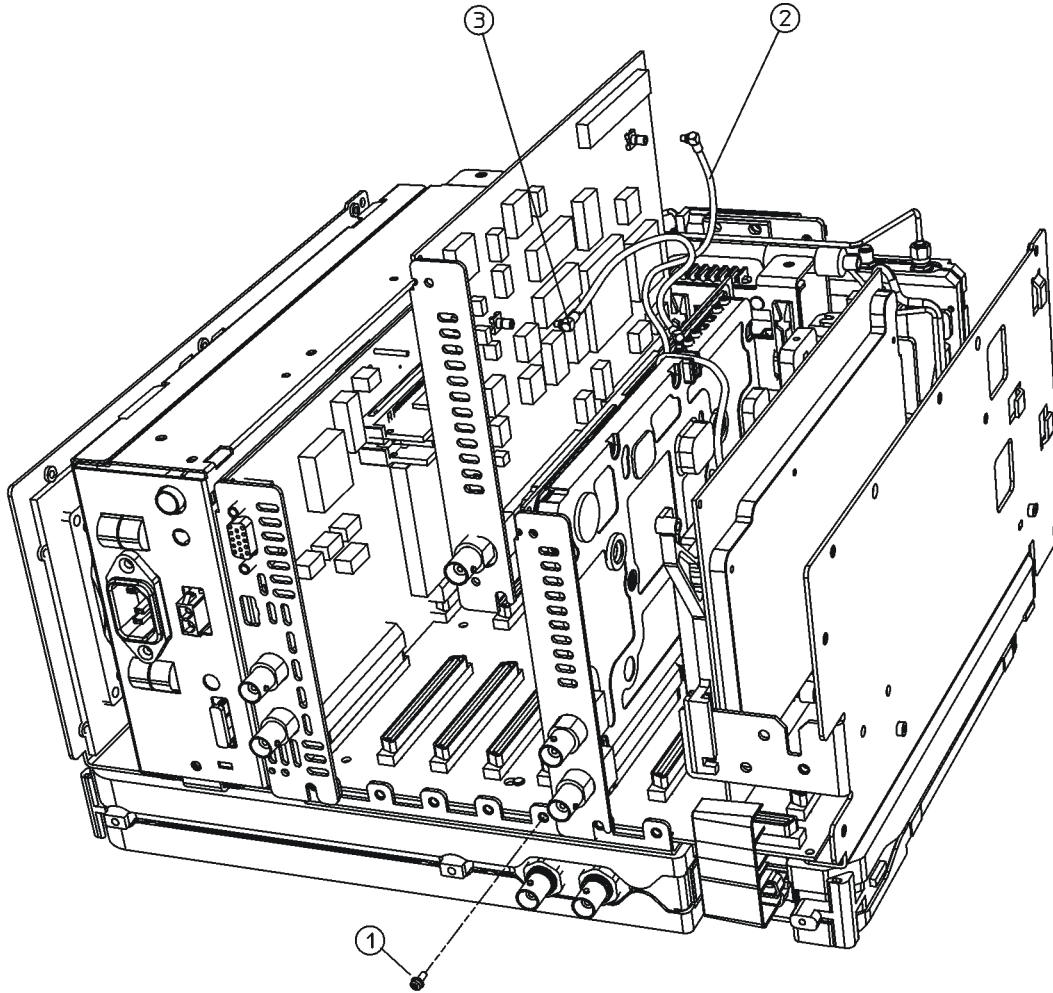

sl73c

11. Lower the A7A7 DSP and FADC Assembly into the card cage being careful not to pinch the cables and plug it into slot 4 on the motherboard.

12. Connect the remaining end of W34 DSP IF cable to A7A8J5 on the A7A8 DDRF Assembly.

13. Refer to [Figure 14](#). Locate the end of W31 coming from the microcircuit area. W31 will have a red label on the end. Connect W31 to A7A8J11 (1).

Figure 14 Cable Connections to A7A8 DDRF Assembly

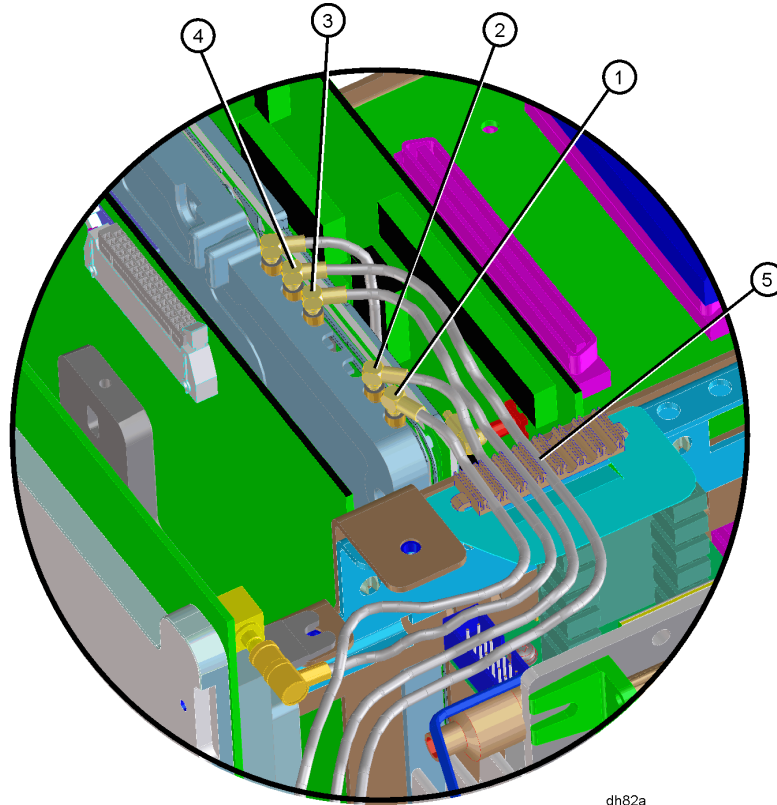

dh82a

14. Locate W32 in the retrofit kit. It will have an SMB connector on one end and an MMCX connector on the other and neither end is labelled. Connect the MMCX end of W32 to A7A8J10 (2). Connect the SMB end of W32 to A3J2 (2) on the A3 IF Assembly.

15. Locate the end of W29 coming from the microcircuit area. W29 will have a brown label on the end. Connect W29 to A7A8J7 (3).

16. Locate the end of W30 coming from the microcircuit area. W30 will have a black label on the end. Connect W30 to A7A8J6 (4).

17. Dress cables W29, W30, W31, and W32 along the top of the A7A8 DDRF board and press the cables into the cable clip (5).

Replace the Support Bar, LO Amp/IF Switch Assembly, Front Frame, and Covers

Replace the Support Bar and LO Amp/IF Switch Assembly

CAUTION CAUTION: Use care not to pinch any cables during reassembly.

1. Refer to [Figure 15](#). Replace the vibration support bar (1) as follows:
 - a. Position the vibration support bar (1) as shown and insert the hook (2) into the IF support arm.
 - b. Engage each hook (3) of the other assemblies or blanks in turn.
 - c. As you position each of the assemblies or blanks, rotate (4) the support bar to lock each one in place.
 - d. Refer to [Figure 16](#). Make sure that the tab (1) is positioned in the slot of the power supply chassis and the vibration bar is fully seated and locked (2) into position.

CAUTION The vibration support bar can be broken easily if it is forced. Install it with care.

Figure 15 Installing the Vibration Support Bar

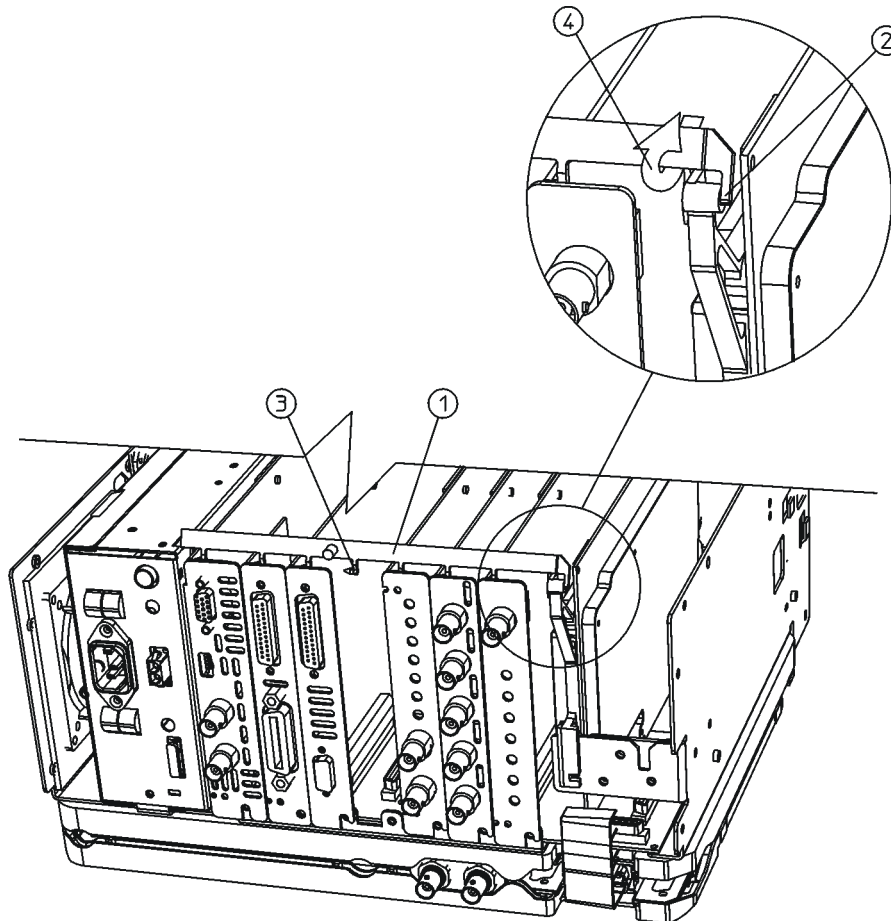

dl76b

Figure 16

Seating the Vibration Support Bar

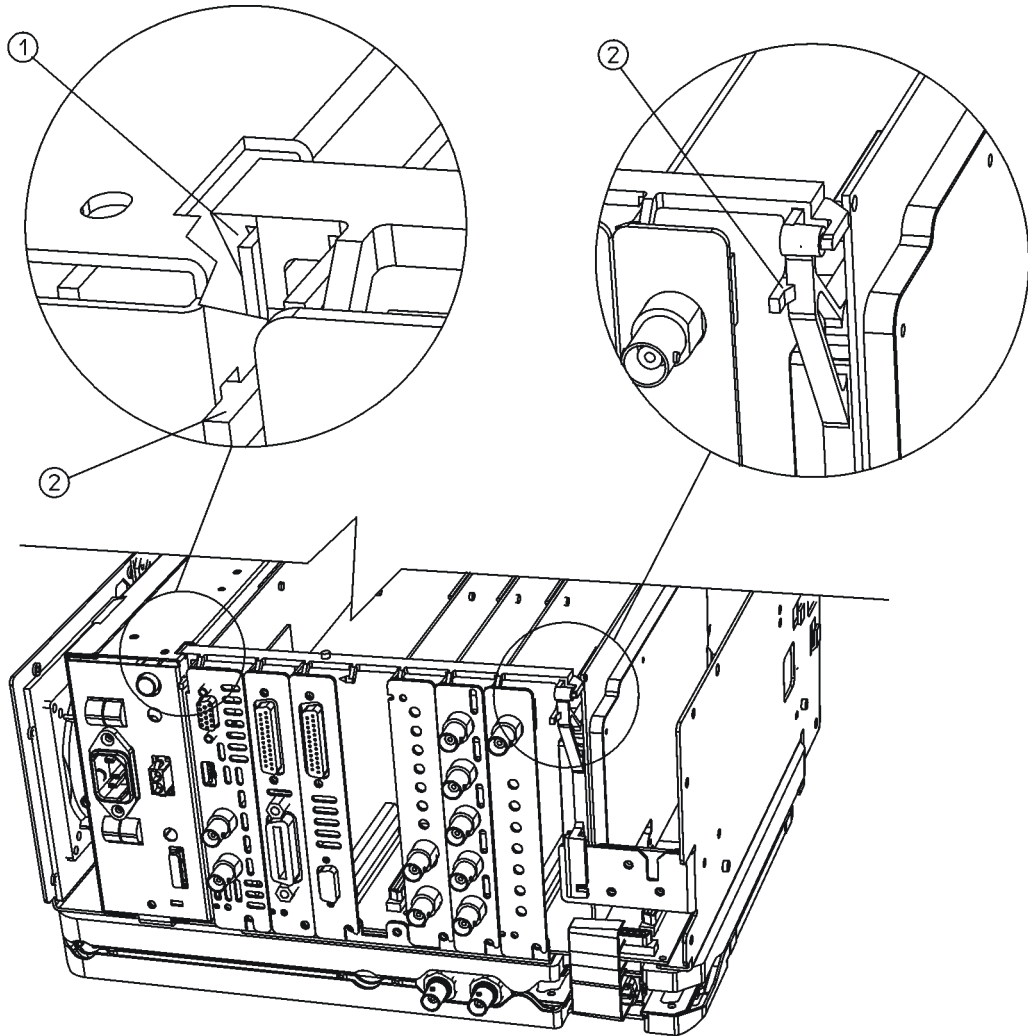

d173b

2. Tighten all the screws that were loosened in the removal procedure to 101 N-cm (9 in-lb).

3. If the analyzer is an ESA E4402B, continue with the procedure “A1 Front Frame Assembly” on page 8.
4. Refer to [Figure 17](#). Re-install the LO Amp/IF Switch Assembly and secure it in place with the three screws (2). Tighten them to 101 N-cm (9 in-lb).

Figure 17 Re-installing the LO Amplifier/IF Switch Assembly

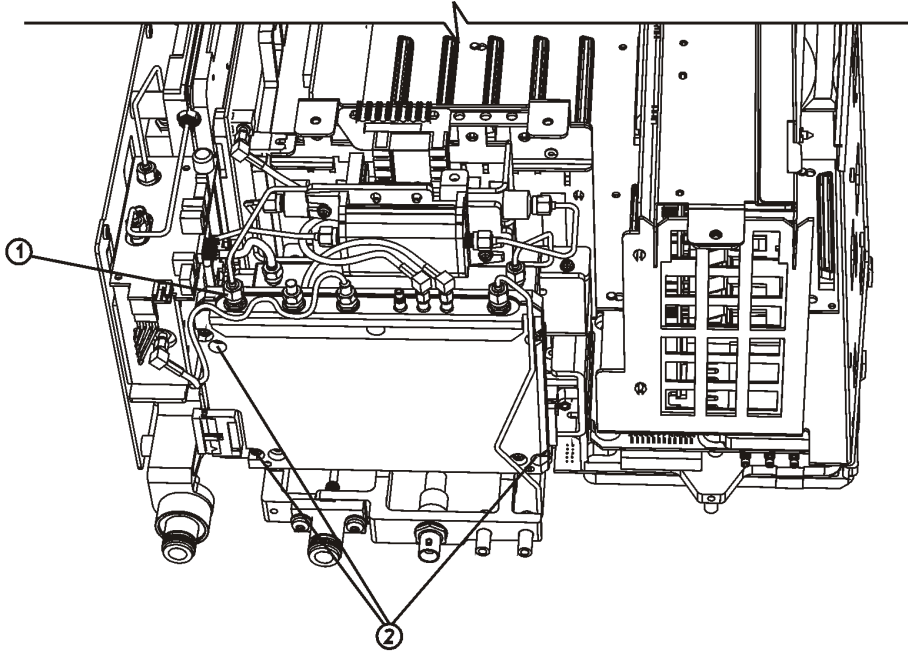

sl775b

5. Reconnect the previously removed cables and loads (1). Tighten the SMA connectors to 95 N-cm (8.5 in-lb).

A1 Front Frame Assembly Replacement

1. Align the A1 Front Frame subpanel rails with the chassis as shown in [Figure 18](#).

Figure 18 **A1 Front Frame Assembly Replacement**

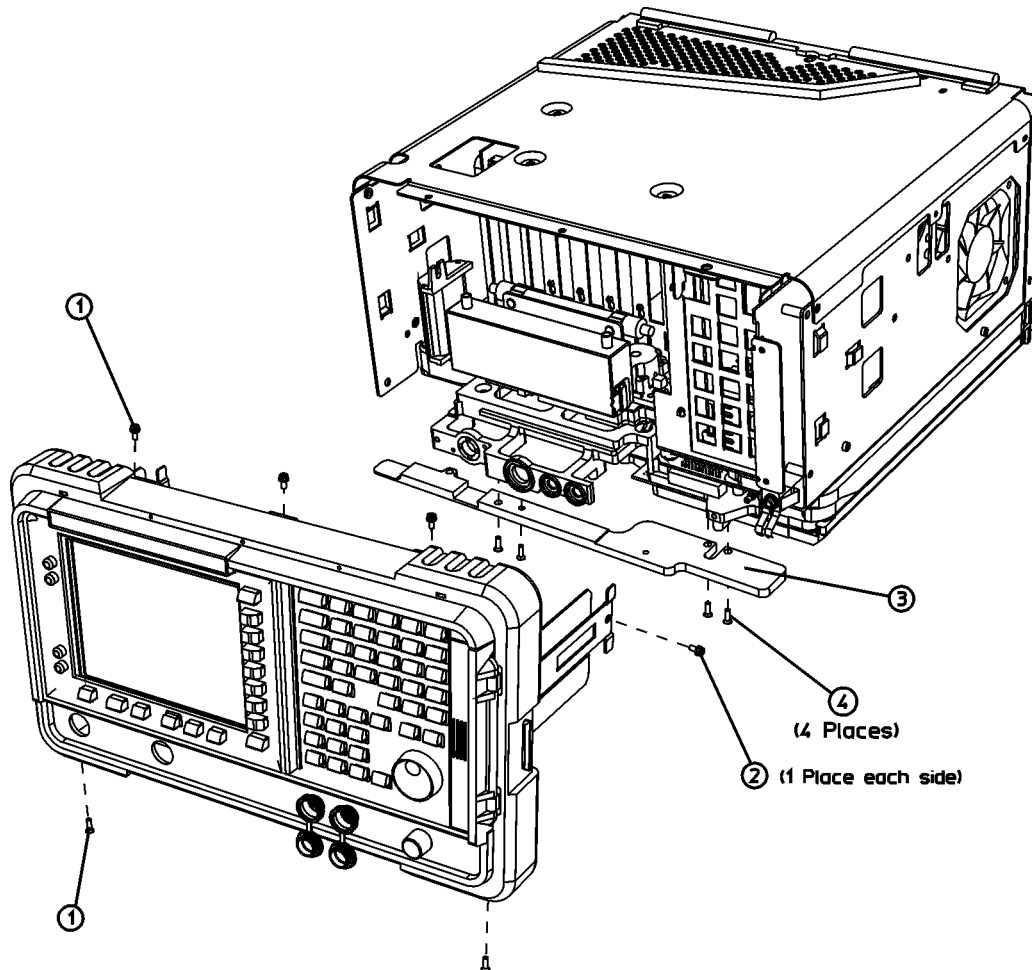

sl7118b

2. Refer to [Figure 19](#). Connect the ribbon cable (1) to the front frame assembly. If Option B7B is installed, there will be two ribbon cables to connect.

Figure 19 **Front Frame Ribbon Cable**

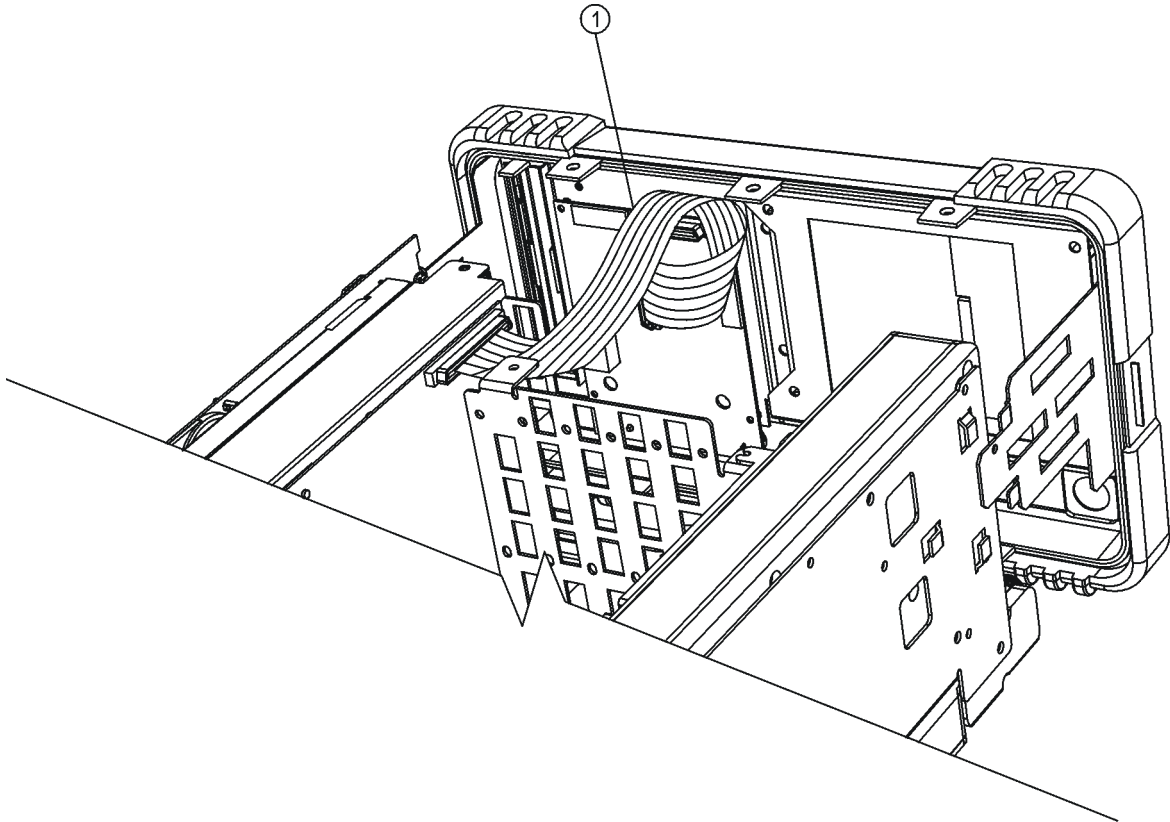

sl749b

3. Carefully slide the front frame toward the chassis, assuring the ribbon cable(s) are not pinched between assemblies, and the RF input connector lines up correctly with the opening in the front frame.

NOTE Make sure the water seal is still in place around the input connector (and around the A2 tracking generator connector if the analyzer has Option 1DN) before reinstalling the front frame assembly.

4. Refer to [Figure 18](#). Replace the screws (1) that secure the front frame to the chassis. Tighten them to 101 N-cm (9 in-lb).

Chassis Cover and Dress Cover Replacement

1. Refer to [Figure 20](#). Carefully position the chassis cover (1) on the analyzer.

Figure 20 Inner Shield Replacement

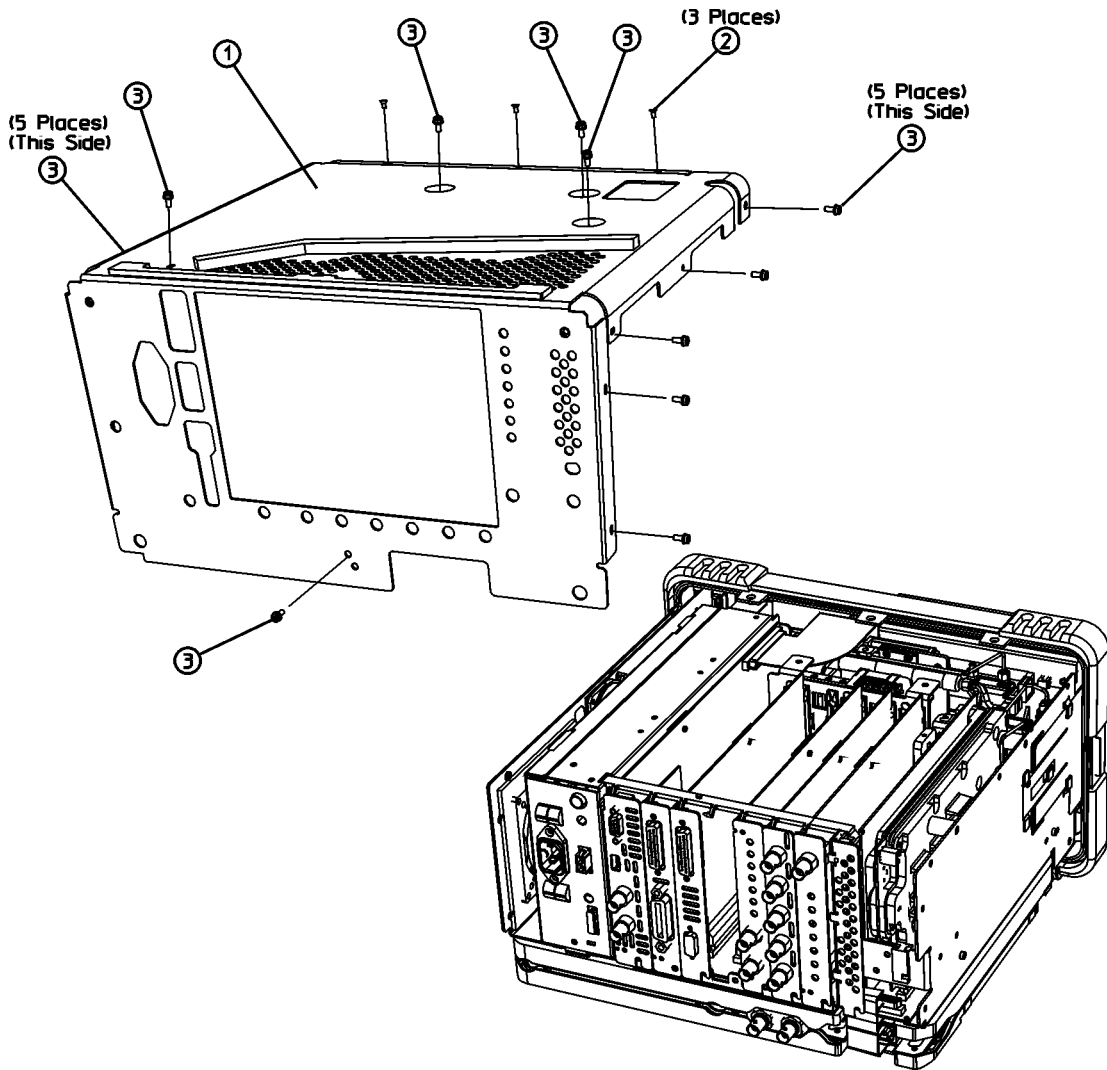

d172b

2. Replace the screws (2) and (3) following the instructions on the chassis cover and tighten them to 101 N-cm (9 in-lb).
3. Carefully place the analyzer on the work surface with the front frame facing down.
4. Replace the analyzer dress cover aligning the grill on the side of the cover to the fan on the A5 power supply assembly.
5. Fit the leading edge of the dress cover completely into the slot on the back of the front frame assembly.
6. Replace the rear frame assembly (6) using the four screws (5) to fasten the rear frame to the analyzer. Tighten the screws to 236 N-cm (21 in-lb).

Revision Verification

1. Verify that Option B72 (Enhanced Memory) is installed in the analyzer. After turning on the analyzer, press **System, More, Show System**. The list of options should include an entry which reads B72: Expansion Memory.
2. If Option B72 is not present, you have three choices:
 - a. If the current firmware revision is A.03.xx or earlier, update the firmware to A.07.06. Revision A.07.06 is the most recent revision which can be used without Option B72. However, you will not be able to install any personalities that make use of Options B7D and B7E. Firmware revision A.07.06 is available from the Web at the following URL:

http://www.agilent.com/find/esa_firmware_std-mem

- b. If the current firmware revision is A.04.xx or later, continue with the Adjustments and Verification procedure below.
 - c. Order the Option B72 Enhanced Memory upgrade kit. Contact your local Agilent Sales and Service Office for more information. The Option B72 upgrade kit includes a firmware update kit.
3. If the analyzer is equipped with Option B72, update the firmware to the latest version, which is available from the web at the following URL:

http://www.agilent.com/find/esa_firmware

Perform Adjustments and Performance Tests

Adjustments Required

The adjustments listed below are required following this upgrade installation. These adjustments can only be performed using the software outlined in the Introduction of this installation note. The adjustments must be performed in the order that they are listed below. They must also be done prior to running any performance verification testing.

- 50 MHz Amplitude Reference Adjustment
- IF Amplitude Adjustment
- Align Now, All (Press **System**, **Alignments**, **Align Now**, **All**)

Performance Testing Required

The performance tests listed below are the minimum recommended set that will verify the upgrade just installed is functioning correctly. Performing these tests alone does not guarantee that the instrument meets all advertised performance specifications. The performance test procedures can be found in the ESA Spectrum Analyzer Calibration Guide, or the tests can be performed using the software outlined in the Introduction of this installation note.

- Displayed Average Noise Level
- Residual Responses
- Frequency Response
- Absolute Amplitude Accuracy (Reference Settings)
- Overall Amplitude Accuracy
- Comms Frequency Response
- Comms Absolute Power Accuracy

NOTE **A full calibration is required to ensure the instrument meets all advertised performance specifications.**

Accessories Supplied in this Retrofit Kit

This retrofit kit includes accessories that should be returned to the user along with the spectrum analyzer. These accessories include:

- A short BNC cable. This cable is used to connect the 10 MHz OUT from the A7A8 DDRF Assembly to the 10 MHz REF IN. An external reference can then be connected to the EXT REF IN port on the A7A8 DDRF Assembly. The EXT REF IN can accept any reference frequency from 1 MHz to 30 MHz.